

# TWIN MACERATOR VERTICAL DRIBBLE BAR / BAND SPREADER



## Description:

- › Available in 10m, 12m and 16m
- › Two Mastek SuperCut Micro macerators
- › Double door access to macerator with stone trap
- › Fits any tanker with linkage
- › LS load sensing hydraulics come as standard
- › Hydraulic break-away boom
- › Lightweight and durable
- › 100% galvanised
- › LED Lights

## Optional Extras:

- › Anti-drip system
- › Touch screen operating system
- › Splashplate
- › Mastek SmartSpread app



### Product Specifications

	10m	12m	16m
<b>Working Width</b>	10m	12m	16m
<b>Transport Width</b>	2.43m	2.42m	2.42m
<b>Transport Height</b>	2.7m	3.3m	4.19m
<b>No. of Outlets</b>	40	48	56
<b>Weight</b>	1150Kg	1380Kg	1780Kg

**Twin Macerator Vertical Dribble Bar/Band Spreader (10m/12m/16m)**

[mastek.ie](http://mastek.ie)

T. +353 49 5555953  
E. [enquiries@mastek.ie](mailto:enquiries@mastek.ie)

**Mastek Ltd,**  
Cootehill Business Park  
Cornacarrow, Cootehill  
Co. Cavan  
H16 DX45  
Ireland

**Mastek Ltd. UK**  
Harmer Hill  
Shrewsbury  
Shropshire  
SY4 3EL  
United Kingdom

**Our ambition is to cut emissions!**

# MASTEK SUPERCUT MACERATOR

*Patent Pending*

- › Capable of cutting high-fibre slurry
- › Even outlet distribution
- › 2.5m of long-life combined blade edge
- › Individual air breathers for each outlet pipe
- › Available with 28, 40 or 48 outlets
- › Low maintenance
- › Easy access door
- › Hydraulic motor protection

*Designed in Ireland  
Manufactured in Ireland  
Proven in extreme  
Irish conditions*

Ø 45MM OUTLET PIPES

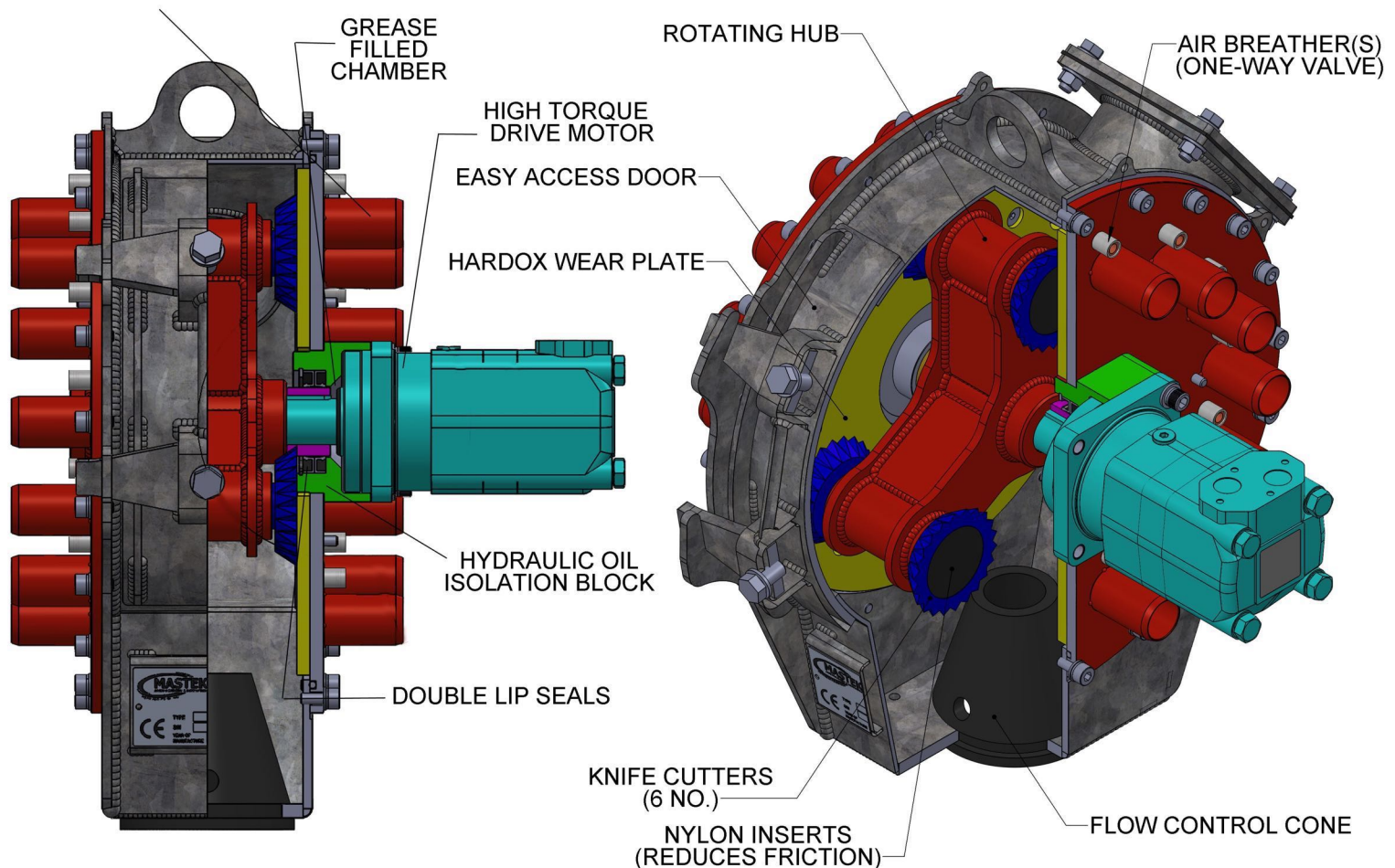

## Mastek SuperCut Macerator

[mastek.ie](http://mastek.ie)

T. +353 49 5555953  
E. [enquiries@mastek.ie](mailto:enquiries@mastek.ie)

**Mastek Ltd,**  
Cootehill Business Park  
Cornacarrow, Cootehill  
Co. Cavan  
H16 DX45  
Ireland

**Mastek Ltd. UK**  
Harmer Hill  
Shrewsbury  
Shropshire  
SY4 3EL  
United Kingdom

**Our ambition is to cut emissions!**